

BA 252 C



Spare parts list

(IDENT-NO. 9 548 953)



PLATON SERVICE
8 (800) 500-34-47
www.platonservice.com

Continental Airlines
NEWARK
AU 06 00213 . 010

INDEX



	Page
01.01 WASH PUMP 4,0 KW CRNI	3
02.01 WASH SYSTEM	5
05.01 FRESH WATER FINAL RINSE, FROM ABOVE	6
05.02 FRESH WATER FINAL RINSE, Laterally	7
05.03 FRESH WATER FINAL RINSE, FROM BELOW	8
07.01 CSS PLUS	9
08.01 FEET OF MACHINE	10
08.02 FEET OF MACHINE	11
09.01 DOOR	12
09.02 DOOR	13
10.01 CURTAIN	14
11.01 DRAINAGE SIEVE TANK	15
11.02 SIEVE DRAWER - BELT DRIVE	16
12.01 DRAIN	17
13.01 FLOAT SWITCH, 90°	18
15.01 BELT DRIVE - FINAL SWITCH	19
16.02 TRANSPORT BELT	20
17.03 BELT DRIVES Ø 60	21
20.02 CHAIN WHEELS	22
21.01 BELT TENSIONING DEVICE	23
22.02 EXTRACTION FAN Ø500	24
23.06 RADIAL FAN	25

KENNZEICHNUNG DER ERSATZTEILE

* / V DIESE TEILE EMPFEHLEN WIR
AUF LAGER ZU LEGEN!
V VERSCHLEISSTEIL!

SPECIAL MARKS OF SPARES

WE RECOMMEND TO STORE THESE
PARTS!
WEAR AND TARE PART!

MARQUAGE SPECIALES DES PIECES

NOUS RECOMMANDONS DE PRENDRE
CES PIECES EN STOCK!
PIÈCE D'USURE!

01.01 WASCHPUMPE 4,0 KW CRNI (50 + 60 HZ)



01.01 WASH PUMP 4,0 KW CRNI

01.01 POMPE DE LAVAGE 4,0 KW CRNI

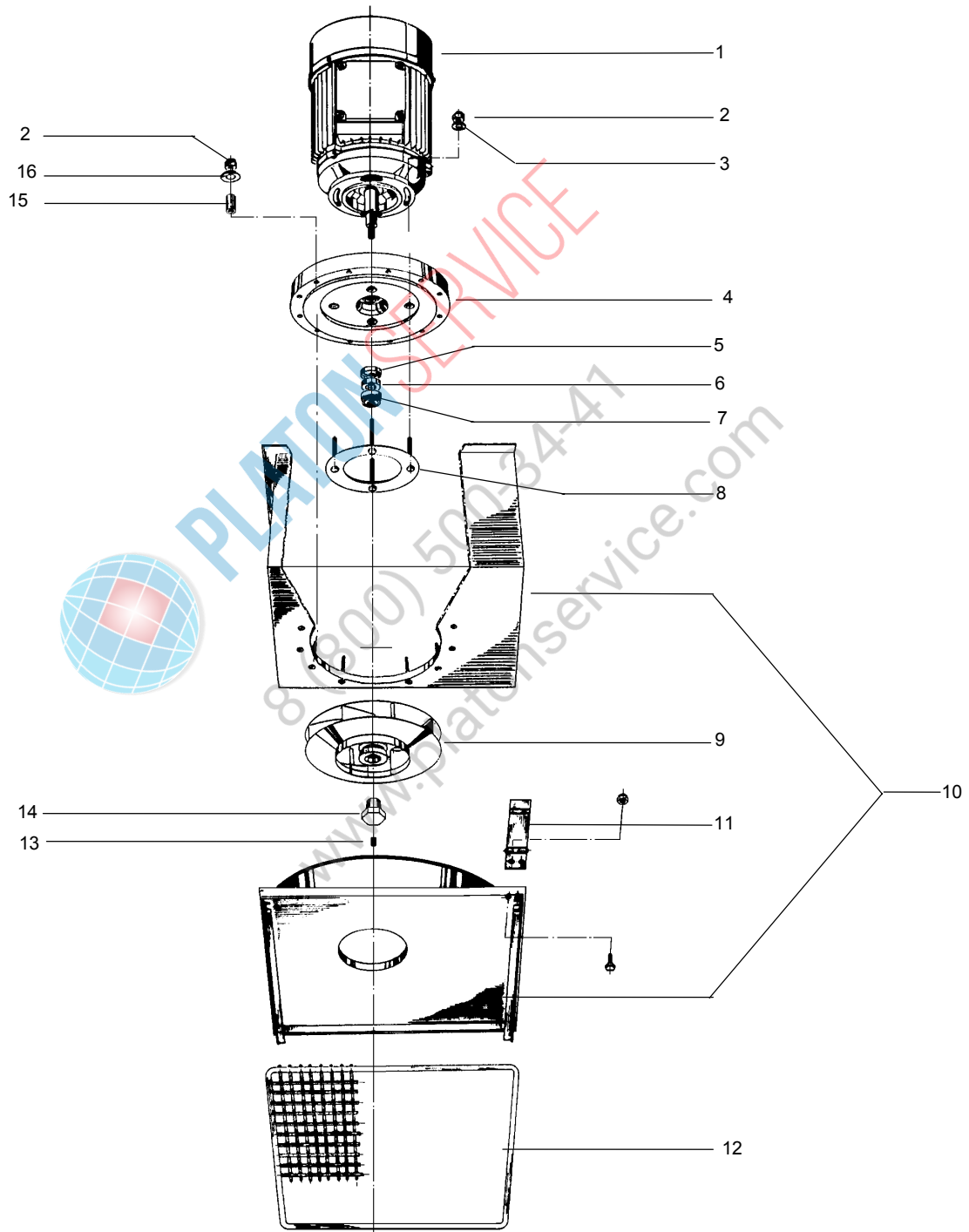

01.01 WASCHPUMPE 4,0 KW CRNI (50 + 60 HZ)



01.01 WASH PUMP 4,0 KW CRNI

01.01 POMPE DE LAVAGE 4,0 KW CRNI

POS	IDENT. NR. IDENT. NO.	BEZEICHNUNG	DESIGNATION	DESIGNATION
1	MOTOR	MOTOR SIEHE ELEKTROSCHALTPLAN	PUMP MOTOR SEE ELECTRIC WIRING DIAGRAM	MOTEUR VOIR SCHEMA ELECTRIQUE
2	0337005	SKT.-MUTTER M 8 SELBSTSICH.	HEXAGON NUT M 8, 4301 DIN 985	ECROU A SIX PANS M8, 4301 DIN 985
3	0340002	U-SCHEIBE 8,4 MM	WASHER 4301 8,4 MM 433	RONDELLE D= 8,4, DIN 433, 4301
4	9604190	MOTORTRÄGER 4 KW-PUMPE PPH D=270X38,5	MOTOR CARRIER PPH D=270X38,5	SUPPORT DE MOT. DE POMPE PPH D=270X38,5
5	V 0403009	GLEITR.-MANSCHETTE WINKEL 30 X 40 X 7 MM 480000008	COLLAR PERBUNAN 30 X 40 X 7 MM 480000008	MANCHETTE PEBUNAN 30 X 40 X 7 MM 480000008
6	V 0403010	GLEITRING KERAMIK 25,9 X 38 X 8 MM	SLIDING SEAL CERAMICS 25,9 X 38 X 8 MM	JOINT AXIAL CERAMIQUE 25,9 X 38 X 8 MM
7	V 0403003	GLEITRINGDICHTUNG VITON 25 X 44 X 20 MM	SLIDING SEAL 25 X 44 X 20 MM	JOINT AXIAL 25 X 44 X 20 MM
8	8250858	FLANSCH-MOTORTRÄGER KPL 4301	MOTOR CARRIER FLANGE CPL. 4301	BRIDE DE SUPPORT DE MO 4301
9	* 8251570	WURFRAD D=185 60 HZ 4301	IMPELLER D= 185 60 HZ	ROUE DE PROTECTION
10	8260678-01	PUMPENGEHÄUSE 4 KW L-R EINBAUSATZ "ERSATZ"	PUMP HOUSING 4 KW L-R REPLACEMENT SET	CORPS DE POMPE 4 KW G-D JEUX DE REMPLACEMENT
11	8251057	SIEBSICHERUNG SCHARNIER	SAFETY DEVICE FOR SIEVE	SECURITE DE TAMIS
12	* 8251058	PUMPENSIEB 308 X 420	PUMP SIEVE 308 X 420	TAMIS DE POMPE 308 X 420
13	0322027	GEWINDESTIFT M.INNEN-6-KT M12X16 MM	HEX-SOCKET SET SCREW M12X16 MM	VIS SANS TETE A 6-PANS CREUX M12X16 MM
14	8100217	MUTTER 4 KW PUMPE 4305 SW 32 X 24	NUT 4KW PUMP 4305 SW 32 X 24	ECROU 4KW POMPE 4305 SW 32 X 24
15	8251059	DISTANZ 4 KW PUMPE D=13X1,5X26,5	DISTANCE 4 KW PUMP D=13X1,5X26,5	PIECE DE DISTANCE P.POMPE D=13X1,5X26,5
16	0340055	U-SCHEIBE 8,4X25X2 MM	WASHER 8,4X25X2 MM	RONDELLE 8,4X25X2 MM

02.01 WASCHSYSTEM



02.01 WASH SYSTEM

02.01 SYSTEME DE LAVAGE

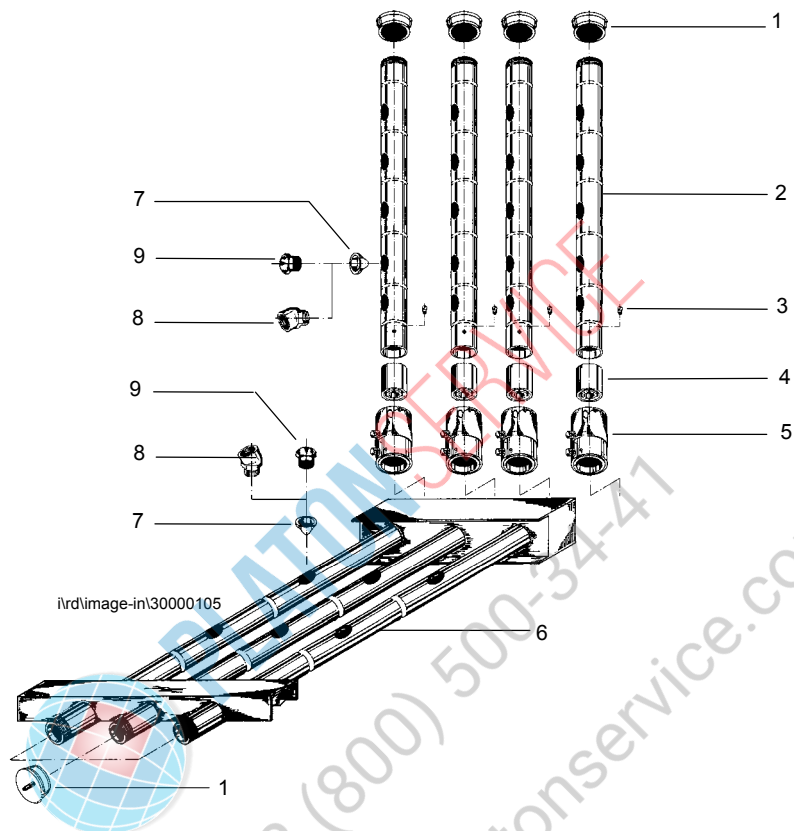

POS	IDENT. NR. IDENT. NO.	BEZEICHNUNG	DESIGNATION	DESIGNATION
1.	* 8102048	VERSCHLUßKAPPE 12/ 1"	END CAP 3/4"4301 D=42X14	CAPUCHON DE FERM. D=42X14
2.	8251541	WASCHROHR SENKRECHT VORM L=1055 10 DÜSEN	VERTICAL WASH ARM L=1055 10 NOZZLE	BRAS DE LAVAGE VERTICALE L=1055 10 GICLEUR
3.	0321015	SCHAFTSCHRAUBE M6 X 15 MM	SCREW M6 X 15 MM	VIS M6 X 15 MM
4.	* 8102022	DROSSEL PPH S DRM 30X14-30	THROTTLE PPH S DRM 30X14-30	REDUCTEUR PPH S DRM 30X14-30
5.	8251236	VERSTELLBAJONETT MIT FEDER	ADJUSTABLE BAYONETT WITH SPRING	BAYONETTE AJUSTABLE AVEC RESSORT
6.	8260666	UNTERES WASCHSYSTEM EINBAUFERTIG AB 11/96	LOWER WASH SYSTEM READY FOR USE	SYSTEME DE LAVAGE INF. PRET A INSTALLER
7.	* 0620161	AUSGLEICHSRING K161	LEVELLING RING K 161	BAGUE COMPENSATRICE K 161
8.	* 0620277	WINKELADAPTER K277	ADAPTER FOR NOZZLES K 277	ADAPTEUR POUR GICLEUR K 277
9.	* 0620207	SCHLITZDÜSE K106/7	LENS SLIT NOZZLE K106/7	GICLEUR A JET LENTI CULAIRE K 106/7

05.01 FRISCHWASSERKLARPÜLUNG, OBEN



05.01 FRESH WATER FINAL RINSE, FROM ABOVE

05.01 RINCAGE FINAL A L'EAU CLAIRE, D'EN HAUT

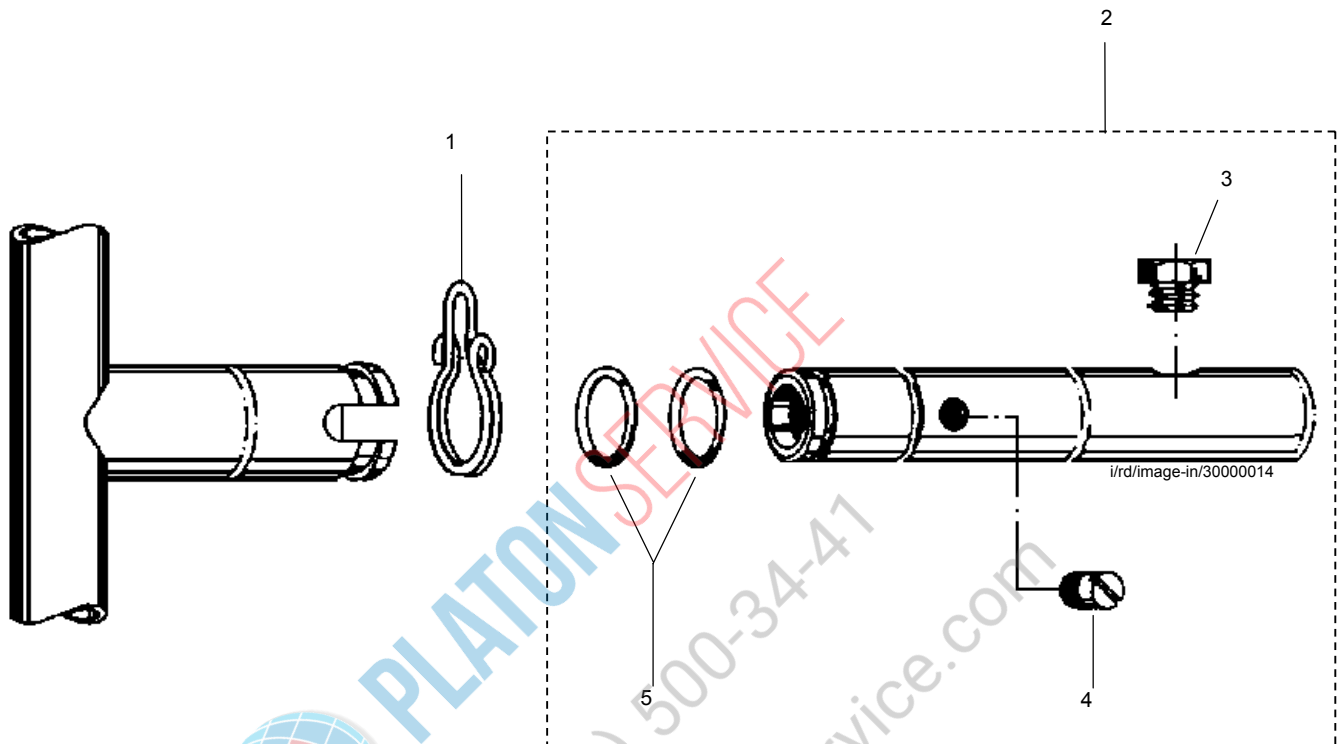

POS	IDENT. NR. IDENT. NO.	BEZEICHNUNG	DESIGNATION	DESIGNATION
1	* 0431050	SICHERUNGSRING B 230-31 16MM F.FRISCHW.NACHSP.ARM	SAFETY RING FOR FINAL RINSE FIXING	BAGUE DE SECURITE POUR FIXATION DE RINCAGE FINAL
2	8251620	NACHSPÜLARM OBEN KPL. L=1100 4 DÜSEN	UPPER FINAL RINSE ARM CPL. L=1100 4 NOZZLES	BRAS DE RINCAGE FINAL INF. L=1100 4GICLEURS
3	* 0472030	DÜSE 1/16" NPT-V-0,3	NOZZLES 1/16" NPT-V-0,3	GICLEURS 1/16"NPT-V-0,3
4	0321015	SCHAFTSCHRAUBE M6 X 16 MM	SCREW M 6X15,DIN 427, 4301	VIS M 6X15,DIN 427, 4301
5	* 0401011	O-RING EPDM/EP6702-1 12X1,5MM	WASHER D = 12 X 1,5	BAGUE O D=12 X 1,5

05.02 FRISCHWASSERNACHSPÜLUNG, SEITLICH



05.02 FRESH WATER FINAL RINSE, Laterally

05.02 RINCAGE FINAL A L'EAU CLAIRE, DE COTE LATERAL

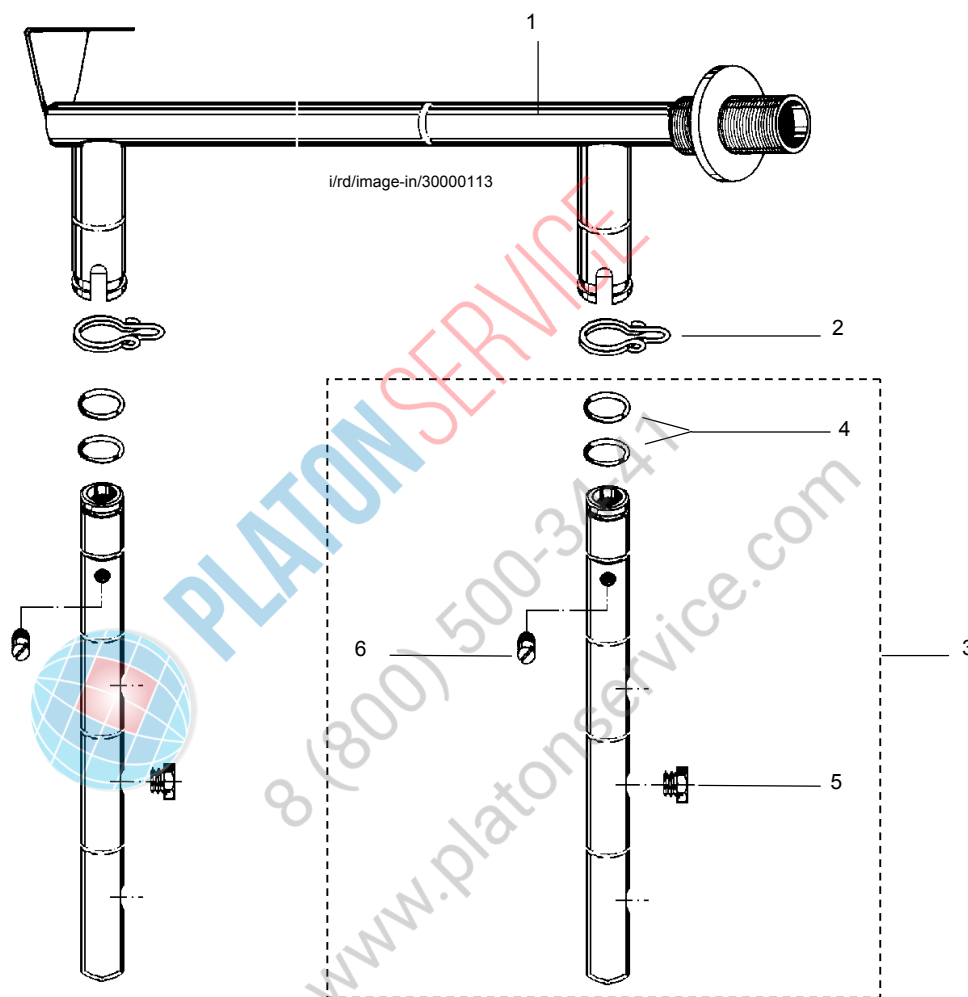

POS	IDENT. NR. IDENT. NO.	BEZEICHUNG	DESIGNATION	DESIGNATION
1	8251615	VERTEILERLEITUNG NSP KPL	DISTRIBUTION PIPE CPL:	TUYAU DE DISTRIBUTION CPL :
2	* 0431050	SICHERUNGSRING B 230-31 16MM F.FRISCHW.NACHSP.ARME	SAFETY RING FOR FINAL RINSE FIXING	BAGUE DE SECURITE POUR FIXATION DE RINCAGE FINAL
3	8251618	NACHSPÜLARME SEITLICH, KPL D=16X2X1000	FINAL RINSE ARM CPL. LATERALLY; D=16X2X1000	BRAS DE RINCAGE FINAL DE COTE LATERAL; D=16X2X1000
4	* 0401011	O-RING EPDM/EP6702-1 12X1,5MM	WASHER D = 12 X 1,5	BAGUE O D=12 X 1,5
5	* 0472030	DÜSE 1/16" NPT-V-0,3	NOZZLES 1/16" NPT-V-0,3	GICLEURS 1/16"NPT-V-0,3
6	0321015	SCHAFTSCHRAUBE M6 X 16 MM	SCREW M 6X15,DIN 427, 4301	VIS M 6X15,DIN 427, 4301

05.03 FRISCHWASSERNACHSPÜLUNG, UNTEN



05.03 FRESH WATER FINAL RINSE, FROM BELOW

05.03 RINCAGE FINAL A L'EAU CLAIRE, D'EN BAS

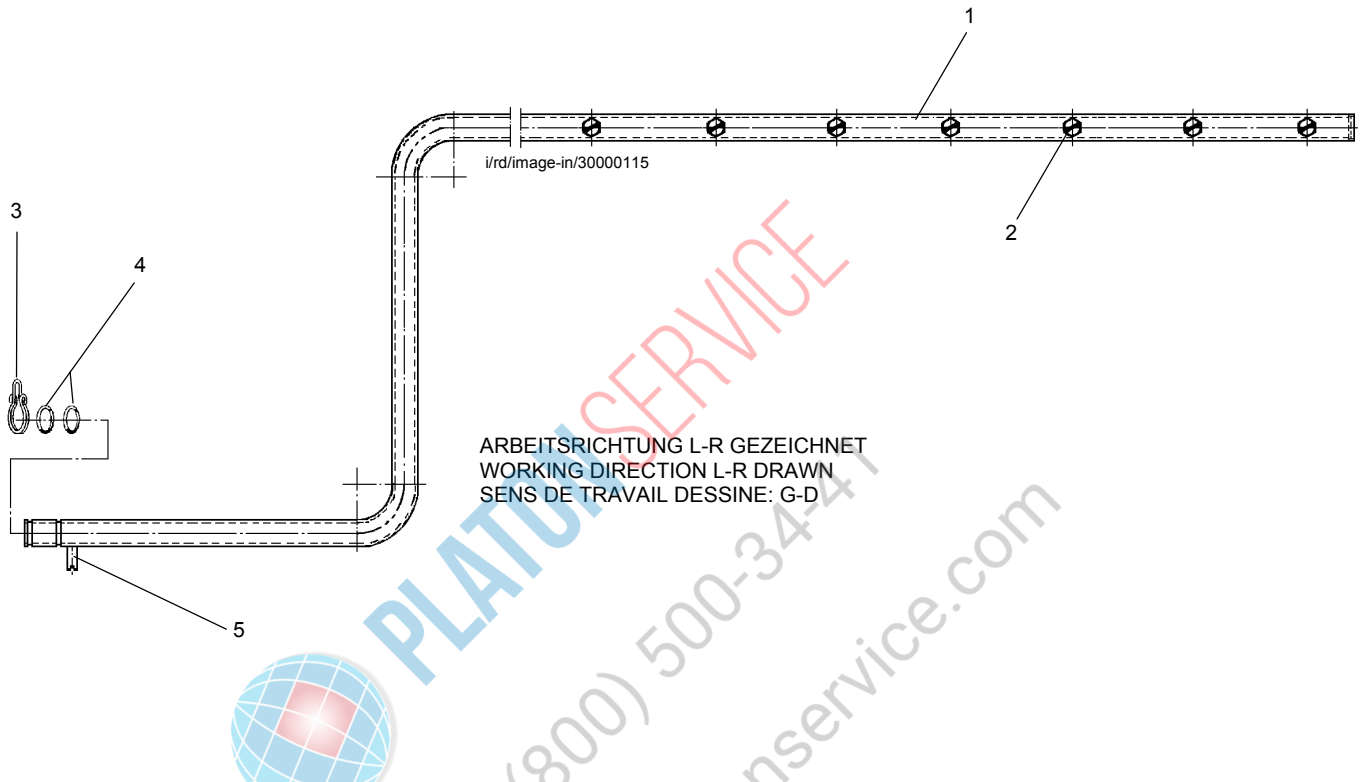

POS	IDENT. NR. IDENT. NO.	BEZEICHNUNG	DESIGNATION	DESIGNATION
1	8260274-01	SPRÜHARM KPL 7 DÜSEN L-R 1.4301 L=1365	FINAL RINSE ARM CPL. 1.4301 L=1365	BRAS DE RINCAGE FINAL CPL. 1.4301 L=1365
2	* 0472030	DÜSE 1/16" NPT-V-0,3	NOZZLES 1/16" NPT-V-0,3	GICLEURS 1/16"NPT-V-0,3
3	0431050	SICHERUNGSRING B 230-31 16MM F.FRISCHW.NACHSP.ARM	SAFETY RING FOR FINAL RINSE FIXING	BAGUE DE SECURITE POUR FIXATION DE RINCAGE FINAL
4	* 0401011	O-RING EPDM/EP6702-1 12X1,5MM	WASHER D = 12 X 1,5	BAGUE O D=12 X 1,5
5	0321015	SCHAFTSCHRAUBE M6 X 16 MM	SCREW M 6X15,DIN 427, 4301	VIS M 6X15,DIN 427, 4301

07.01 CSS PLUS

07.01 CSS PLUS

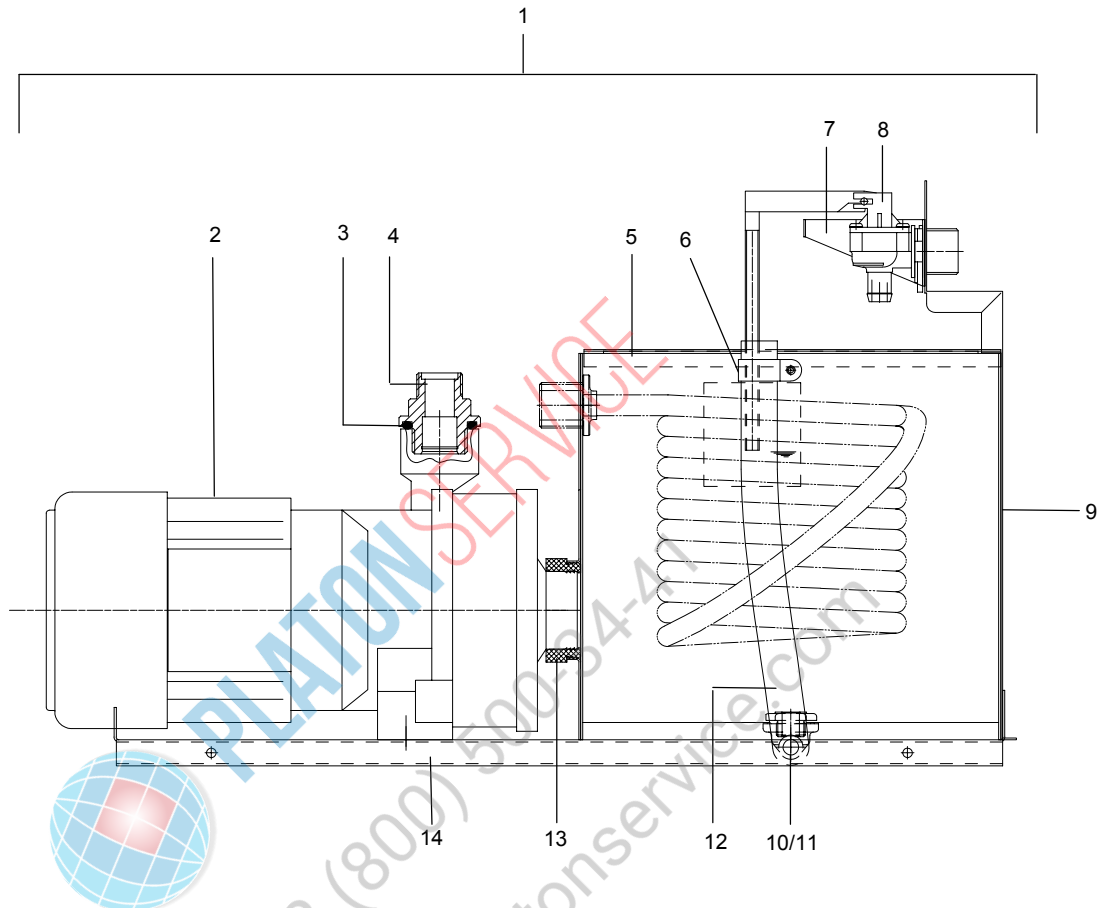

POS	IDENT. NR. IDENT. NO.	BEZEICHUNG	DESIGNATION	DESIGNATION
1	9529530	CSS PLUS KPL.	CSS PLUS CPL.	CSS PLUS CPL.
2	9500488	PUMPE 0242/C	PUMP 0242/C	POMPE 0242/C
3	0408010	DICHTRING GYLON 32X44X1,5 1"	PACKING GYLON 32X44X1,5 1"	JOINT GYLON 32X44X1,5 1"
4	9501608	ADAPTER D47X47 DRUCKSEITE	ADAPTER D47X47 DELIVERY SIDE OF THE PUMP	ADAPTATEUR 47X47 COTE REFOULEMENT POMPE
5	9506964	DECKEL	LID	COUVERCLE
6	0233095	ROHRSCHELLE NR. 3333 CC H 13/16 WEISS	HOSE CLAMP NR 3333 CC H 13/16 WHITE	BRIDE POUR TUYEAU NO. 3333 CC H 13/16 BLANC
7	9511831	HALTEBLECH	FIXING SHEET	DOLE DE FIXATION
8	* 9507283	SCHWIMMERVENTIL	FLOAT VALVE	VANNE-FLOTTEUR
9	9506920	BEHÄLTER	CONTAINER	RECIPIENT
10	9508052	VERSCHRAUBUNG	SCREWED CONNECTION	VISSAGE
11	* 0401066	O-RING 22X3MM SHORE 75°	O-RING 22X3MM SHORE 75°	ANNEAU TORRIQUE D'ETANCHEITE
12	9508149	SCHLAUCHANSCHLUSS	HOSE CONNECTOR	RACCORD DE TUYEAU
13	0650066	MUFFE KD12-K340133 EPDM 60 SHORE SCHWARZ	SLEEVE KD12-K340133 EPDM 60 SHORE BLACK	MANCHON KD12- K340133 EPDM 60 SHORE NOIR
14	9507216	KONSOLE	CONSOLE	CONSOLE

08.01 MASCHINENSTOLLEN



08.01 FEET OF MACHINE

08.01 PIEDS DE MACHINE

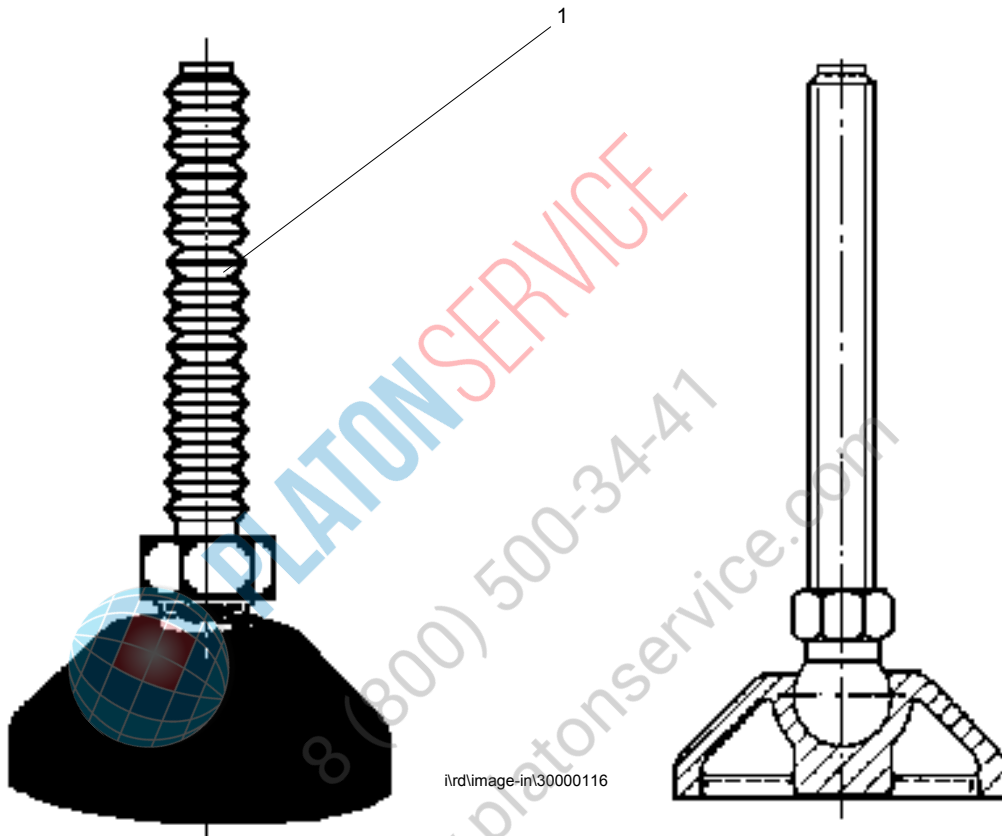

POS	IDENT. NR. IDENT. NO.	BEZEICHNUNG	DESIGNATION	DESIGNATION
1	0460040	GELENKFUSS D 50 VERZ. STANGE M12 L 155 42-17095	FEET WITH BALL JOINT THREADED BAR M12	PIETEMET AVEC ARTICULATION BARRE FILETE M12
2	9500688	GELENKFUSS Ø40	FEET WITH BALL JOINT Ø40	PIETEMET AVEC ARTICULATION Ø40

08.02 MASCHINENSTOLLEN



08.02 FEET OF MACHINE

08.02 PIEDS DE MACHINE

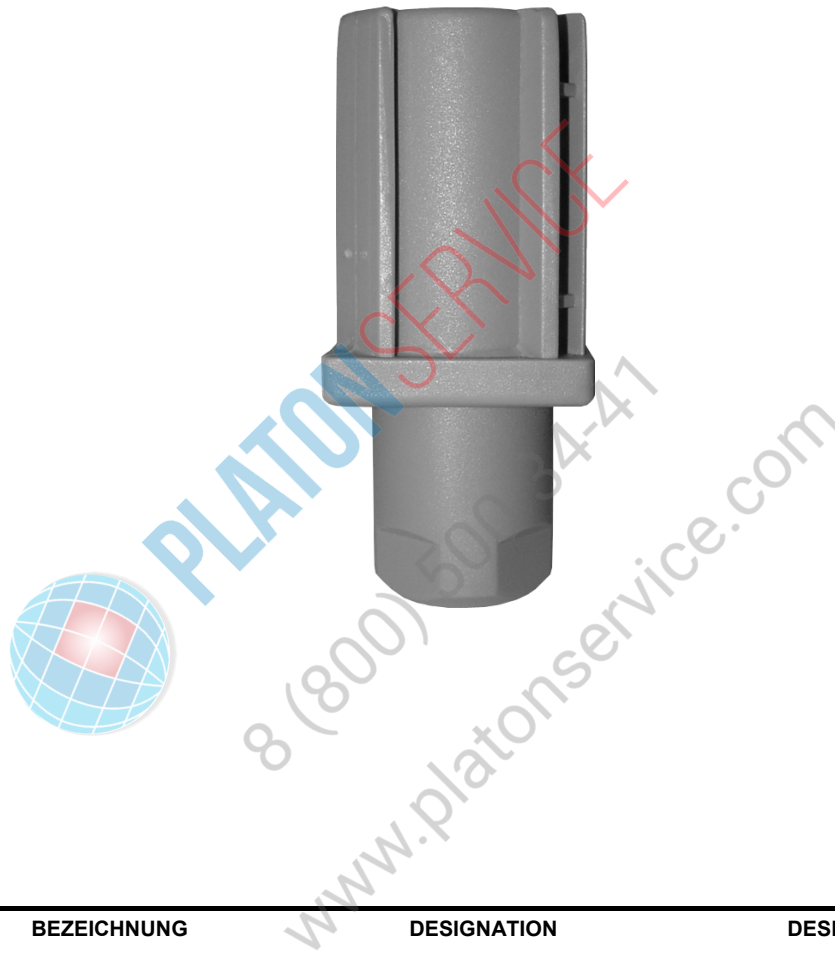

POS	IDENT. NR. IDENT. NO.	BEZEICHUNG	DESIGNATION	DESIGNATION
1	9533829	TISCHSTOLLEN KPL.	TABLE FEET CPL.	PIEDS DE TABLE CPL.

09.01 TÜR

09.01 DOOR

09.01 PORTE

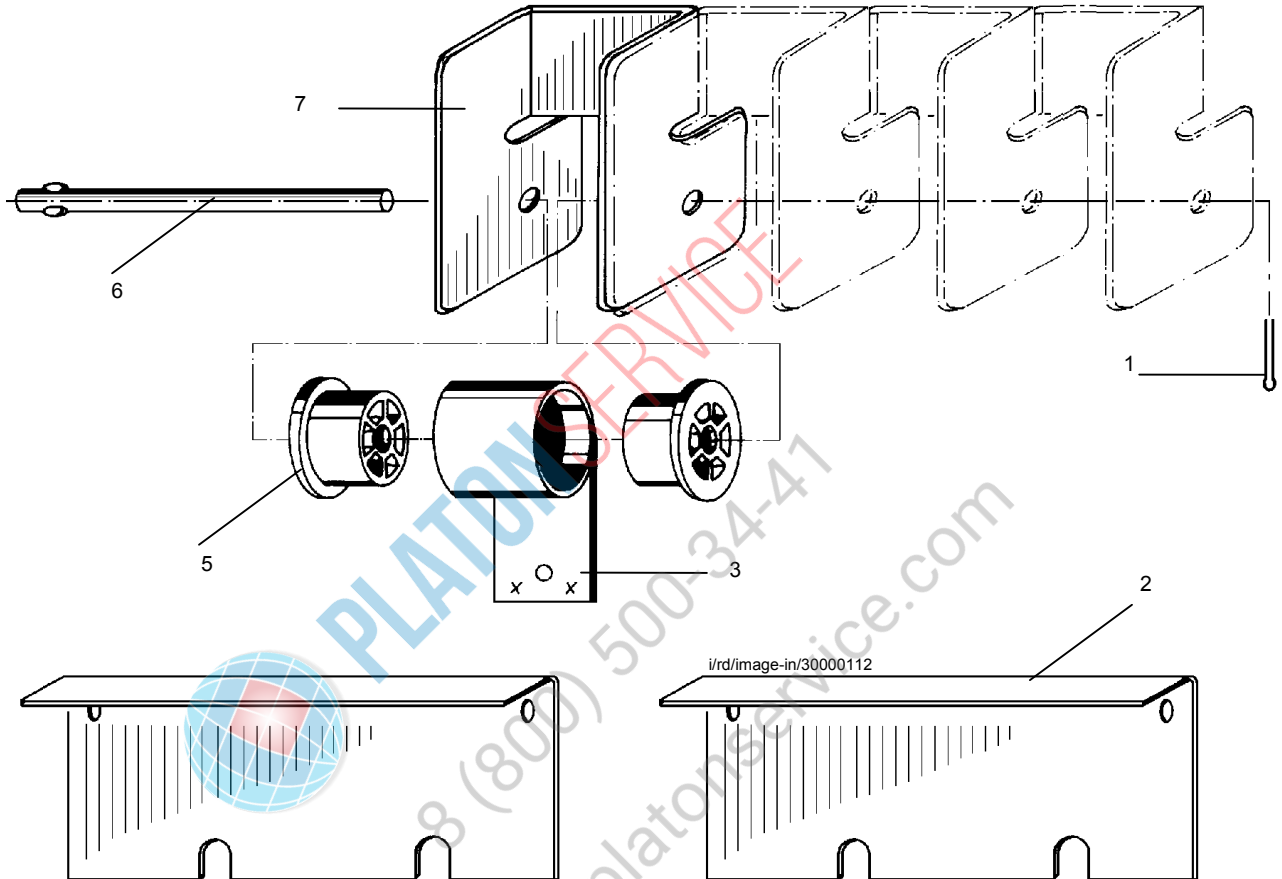

POS	IDENT. NR. IDENT. NO.	BEZEICHUNG	DESIGNATION	DESIGNATION	
1	*	0351004	SPLINT DIN 94 2 X 20 MM 1.4301	SPLIT PIN D= 2 X 20	GOUPILLE D= 2 X 20
2		8100915	TÜRANSCHLAG 181*78*20	DOOR CATCH 181*78*20	ARRET DE PORTE 181*78*20
3	V	0431080	ROLLFEDER 70 N 3 STÜCK / TÜR	ROLLER SPRING 70 N 3 PIECES / DOOR	ROULEAU A TROU 70 N 3 PIECES / PORTE
4	V	0431081	ROLLFEDER 90 N 1 STÜCK / TÜR	ROLLER SPRING 90 N 1 PIECES / DOOR	ROULEAU A TROU 90 N 1 PIECES / PORTE
5	*	0620284	LAGERROLLE 1/2" K280	SUPPORT ROLL 1/2 K 280	ROULEAU SUPPORT 1/2 K 280
6		8100909	LAGERBOLZEN LANG D=8X149	BOLT LONG D=8X149	BOULON D=8X149
7		8100868	ROLLFEDERHALTERUNG 1.4301 60*60,5*95	SCROLL SPRING SUPPORT 1.4301 60*60,5*95	SUPPORT POUR RESSORT A 1.4301 60*60,5*95

09.02 TÜR

09.02 DOOR

09.02 PORTE

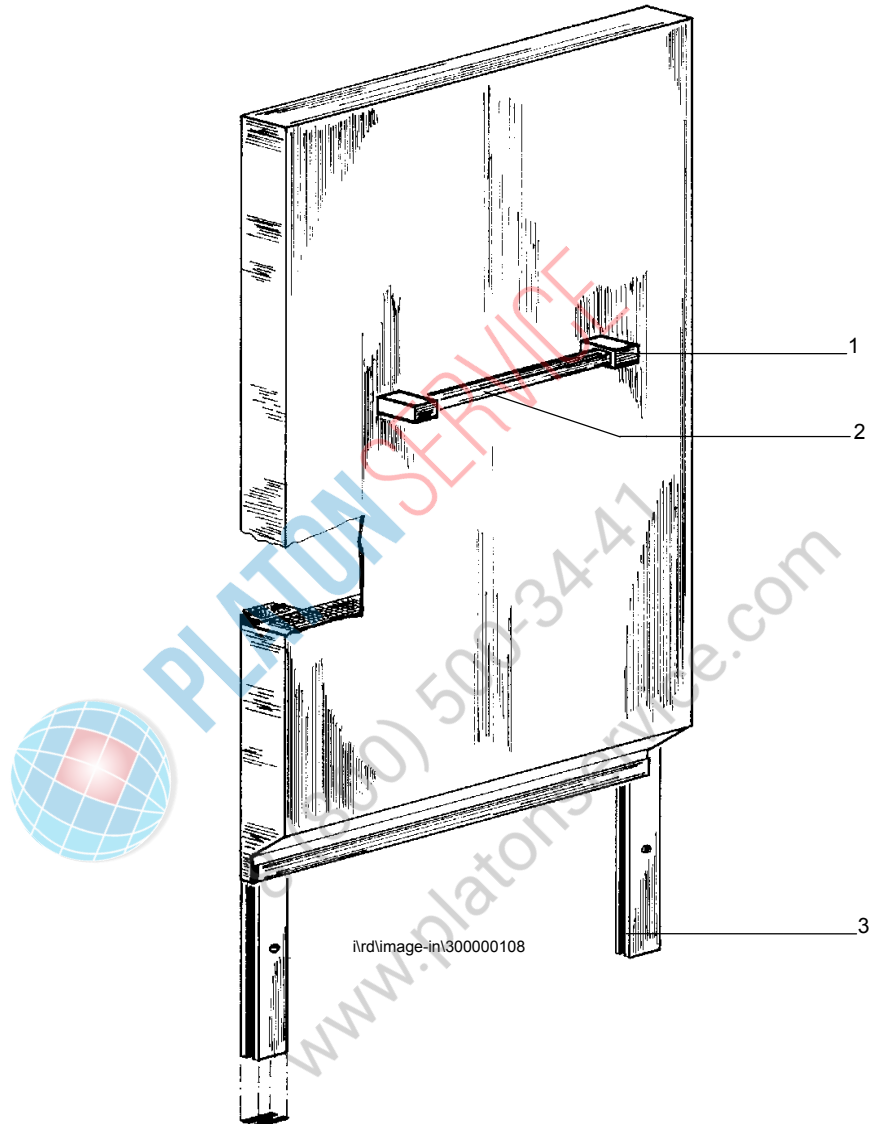

POS	IDENT. NR. IDENT. NO.	BEZEICHUNG	DESIGNATION	DESIGNATION
1	0620222	GRIFFHALTER K222	HANDLE SUPPORT K 222	SUPPORT DE POIGNEE K 222
2	8105002	GRIFSTÜCK,RILSANIERT ST37.2 VKT20-382	HANDLE ST37.2 VKT20-382	POIGNEE ST37.2 VKT20-382
3	8251507	FÜHRUNGSSCHIENE,TÜR S SCHW. 30X12.8X1295	GUIDING RAIL / DOOR S SCHW. 30X12.8X1295	RAIL DE GUIDAGE / PORTE S SCHW. 30X12.8X1295

10.01 VORHANG

10.01 CURTAIN

10.01 RIDEAU

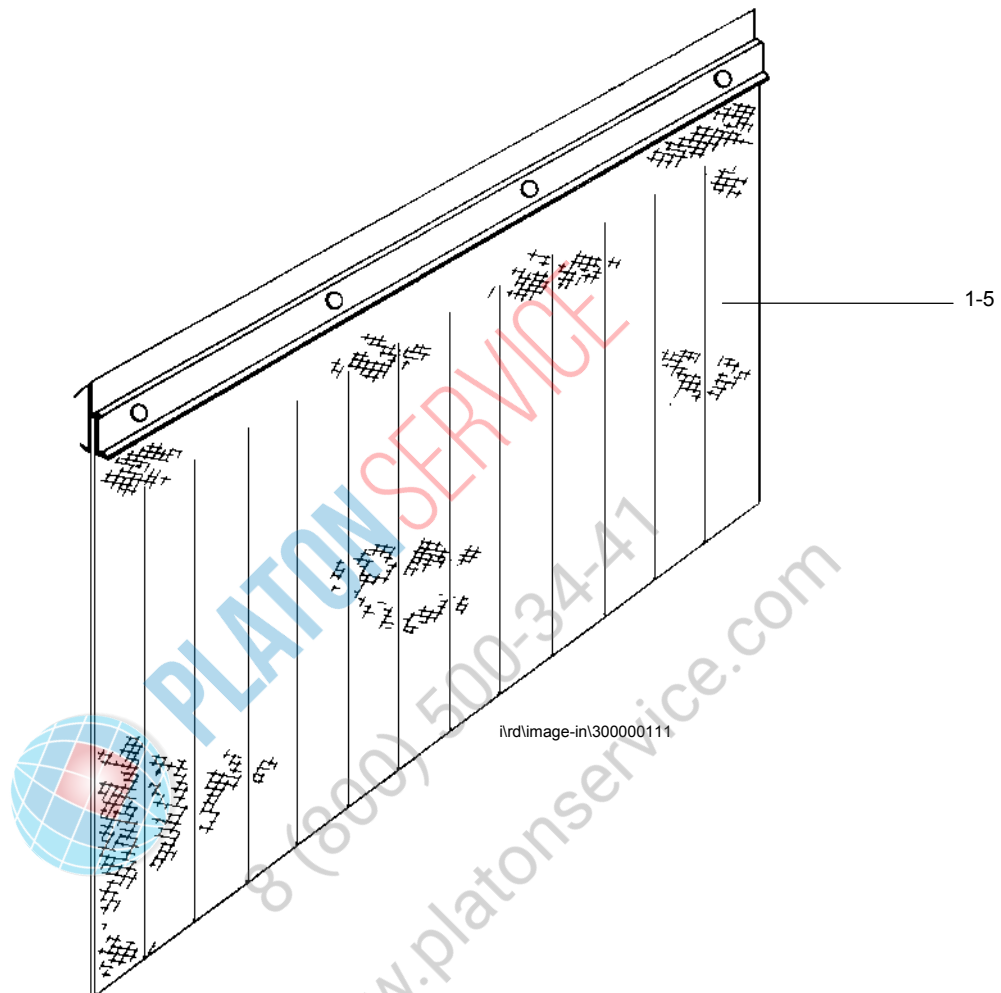

POS	IDENT. NR. IDENT. NO.	BEZEICHNUNG	DESIGNATION	DESIGNATION
1	V 8254059	VORHANG KPL 600X670 EINLAUF	SPLASH CURTAIN 600X670 MM FEEDING SECTION	RIDEAUX CPL. 600X670 MM ZONE D'ENTREE
2	V 8254060	VORHANG KPL 660X520 TANK 1	SPLASH CURTAIN 660X520 MM TANK 1	RIDEAUX CPL. 660X520 MM BAC 1
3	V 8254060	VORHANG KPL 660X520 TANK 2	SPLASH CURTAIN 660X520 MM TANK 2	RIDEAUX CPL. 660X520 MM BAC 2
4	V 8254060	VORHANG KPL 660X520 TROCKNUNG ANFANG	SPLASH CURTAIN 660X520 MM DRYING BEGINNING	RIDEAUX CPL. 660X520 MM SECHAGE DEBUT
5	V 8254061	VORHANG KPL 660X800 TROCKNUNG ENDE	SPLASH CURTAIN 660X800 MM DRYING END	RIDEAUX CPL. 660X800 MM SECHAGE FIN

11.01 ABLAUFSIEB TANK



11.01 DRAINAGE SIEVE TANK

11.01 TAMIS DE VIDANGE DE BAC

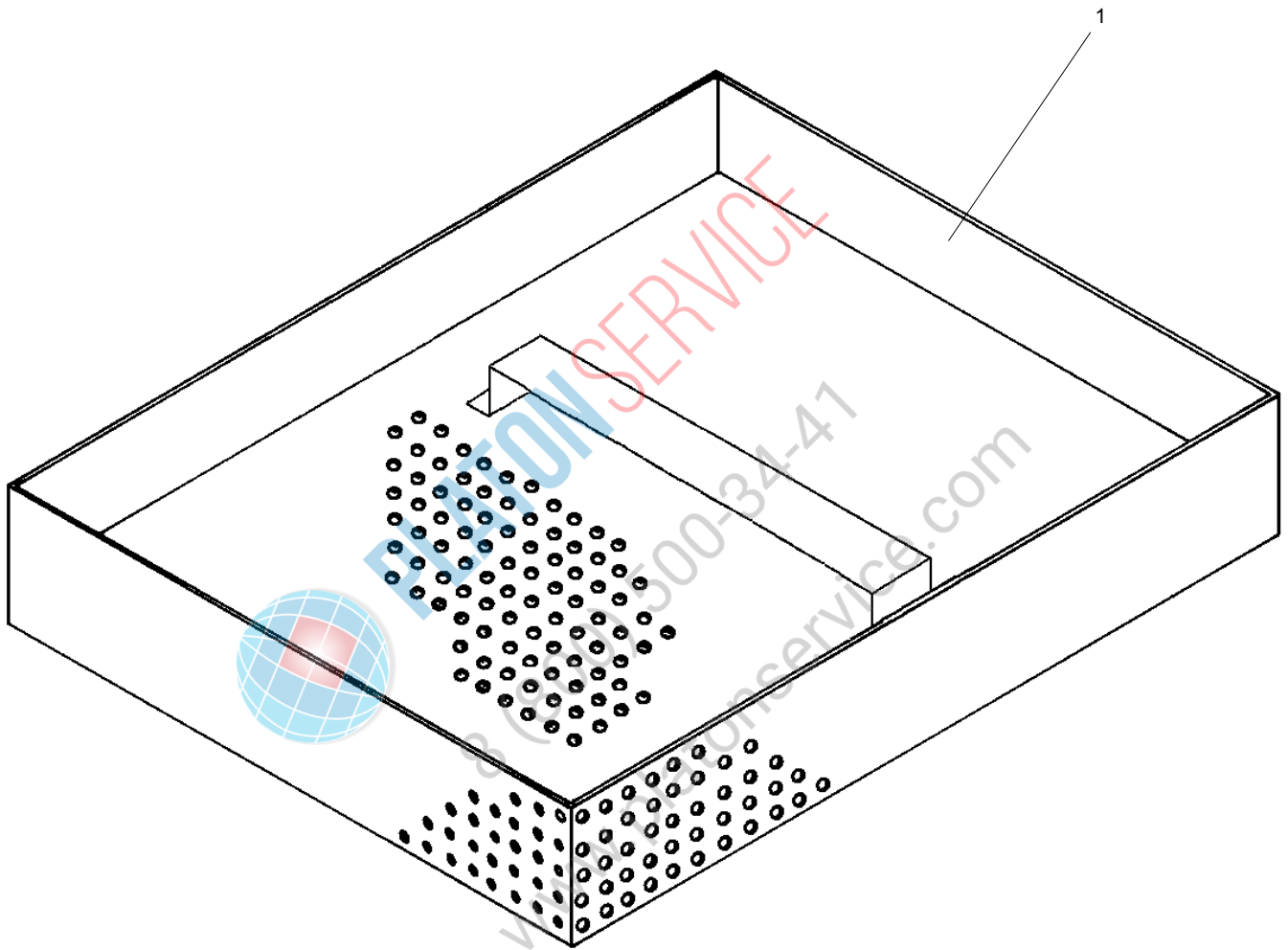

POS	IDENT. NR. IDENT. NO.	BEZEICHNUNG	DESIGNATION	DESIGNATION
1	8251591	ABLAUFSIEB, KPL. 1.4301 246X196X40	DRAINAGE SIEVE 1.4301 246X196X40	TAMIS DE VIDANGE 1.4301 246X196X40

11.02 SIEBKORB - BANDANTRIEB



11.02 SIEVE DRAWER - BELT DRIVE

11.02 TAMIS FILTRE - ENTRAINEMENT DE CONVOYEUR

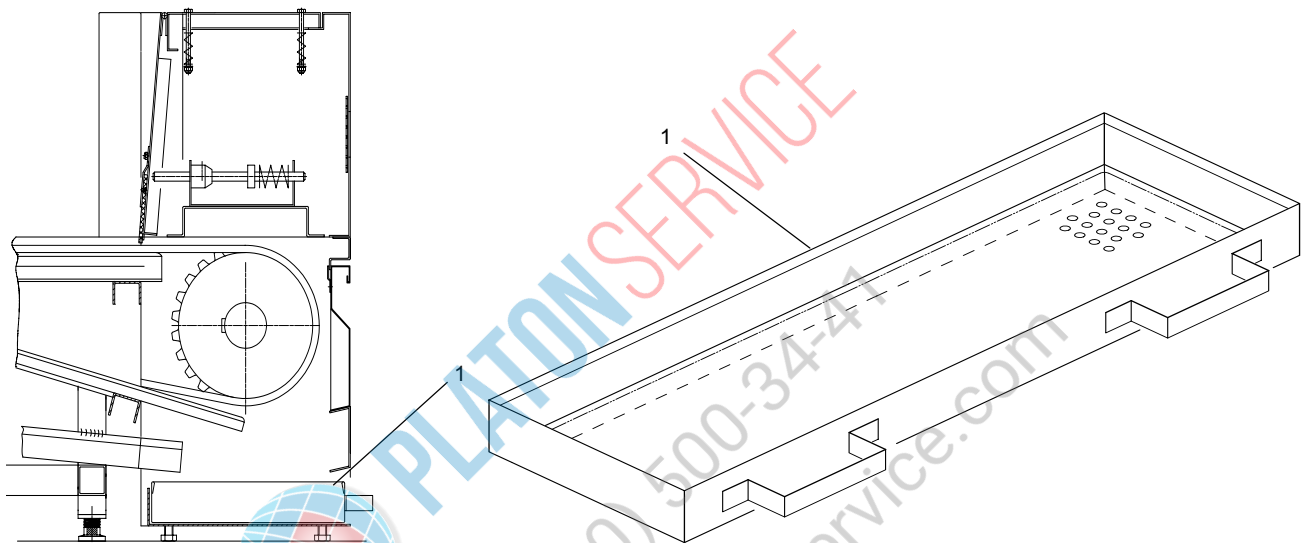

POS	IDENT. NR. IDENT. NO.	BEZEICHUNG	DESIGNATION	DESIGNATION
1	8252190	SIEBKORB 1060 X 280 X 56	SIEVE DRAWER 1060 X 280 X 56	TAMIS FILTRE 1060 X 280 X 56

12.01 ABLAUF

12.01 DRAIN

12.01 VIDANGE

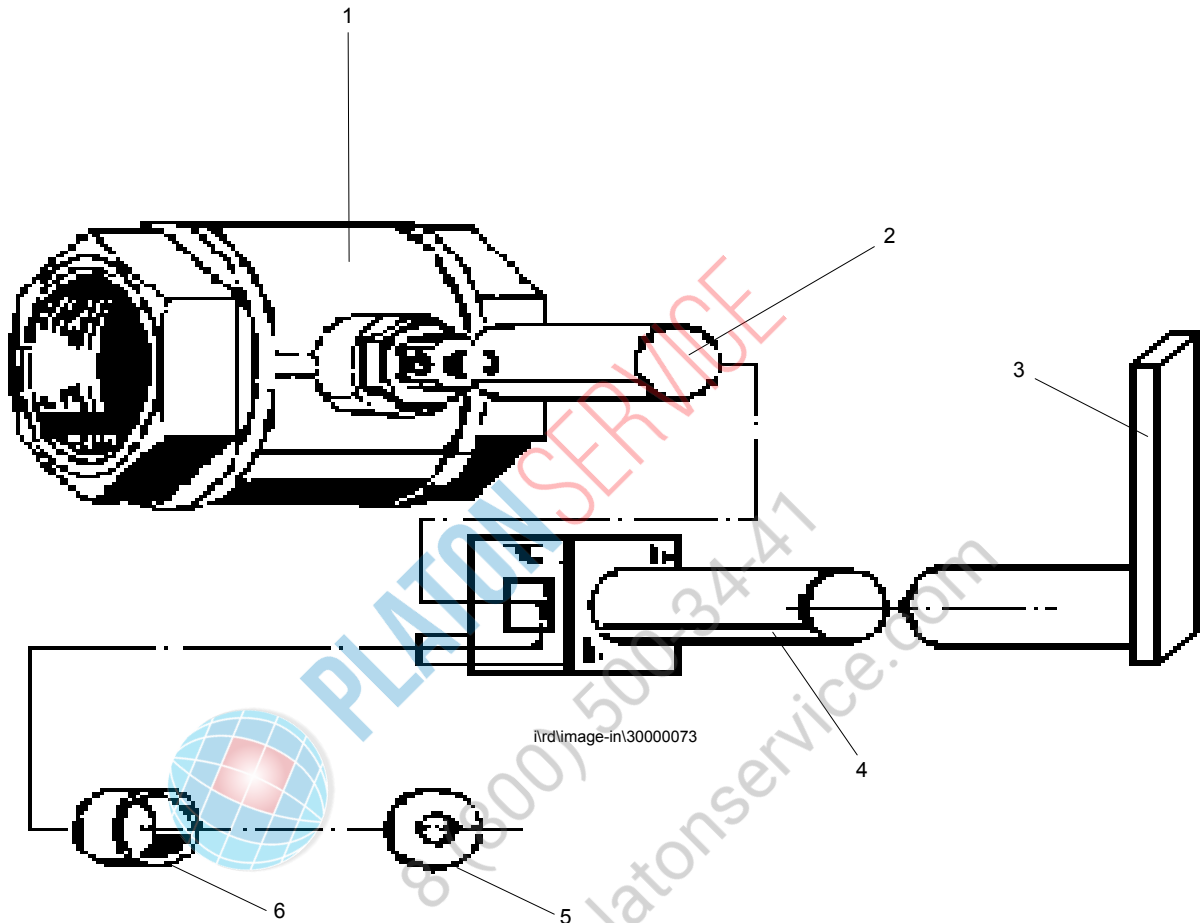

POS	IDENT. NR. IDENT. NO.	BEZEICHNUNG	DESIGNATION	DESIGNATION
1	0237045	KUGELHAHN 2" MS VERN. LÄNGE 111 MM	BALL VALVE 2" RED BRASS	ROBINET A BOISSEAU 2" LAITON
2	8254725	VERLÄNGERUNG-KUGELHAHN 1.4301 D20-240	EXTENSION BALL VALVE 1.4301 D20-240	PROLONGATION ROBINET A 1.4301 D20-240
3	8254418	GRIFF	HANDLE	POIGNEE
4	8100374	VERRIEGELUNGSBLECH R-L	LOCK SHEET	TOLE DE VERROUILLAGE
5	8100375	DRUCKSCHEIBE D = 24 X D = 7 X2	PRESSURE DISK D = 24 X D = 7 X2	RONDELLE DE PRESSION D = 24 X D = 7 X2
6	8100377	DISTANZROHR D = 24 X 3 X 7	EXTENSION OF BALL VALVE D = 24 X 3 X 7	PROLONGATION DE ROBINET A BOISSEAU D = 24 X 3 X 7

13.01 SCHWIMMERSCHALTER, 90°



13.01 FLOAT SWITCH, 90°

13.01 INTERRUPTEUR FLOTTANT, 90°

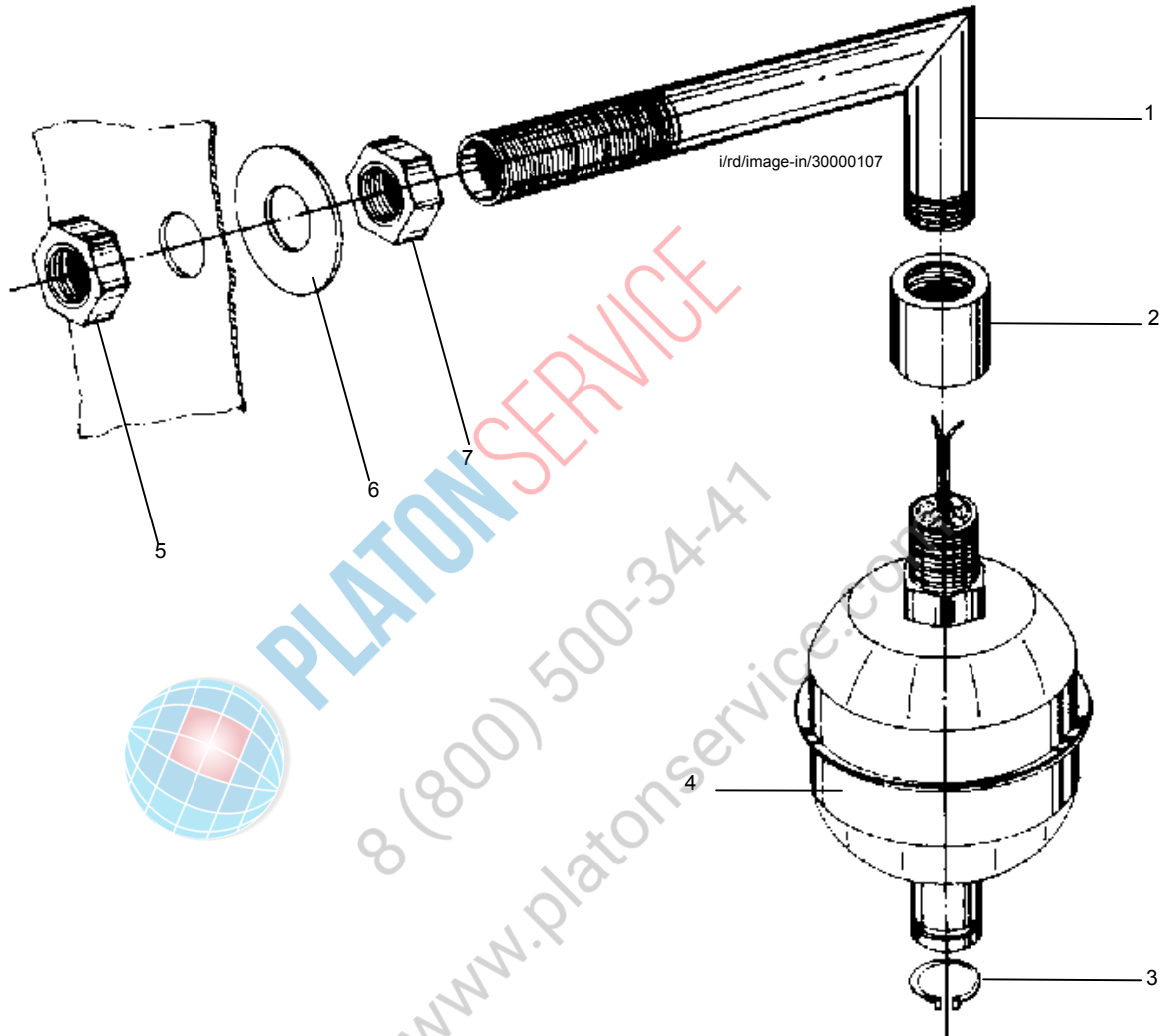

POS	IDENT. NR. IDENT. NO.	BEZEICHNUNG	DESIGNATION	DESIGNATION
1	8255524	DOPPELNIPPEL R=1/4" 1.4301 SCHWIMMERSCHALTER	DOUBLE NIPPLE R=1/4" 1.4301 FLOAT SWITCH	NIPPLE DOUBLE R=1/4" INTERRUPTEUR FLOTTANT
2	8250807	MUFFE R=1/4" D=17X15 1.4301	SOCKET R=1/4" D=17X15 1.4301	MANCHON R=1/4" D=17X15 1.4301
3	0343003	SICHERUNGSRING FEDERSTAHL 12 MM DIN 471	SAFETY RING SPRING STEEL 12 MM DIN 471	BAGUE DE SECURITE 12 MM DIN 471
4	* 0130023	SCHWIMMERSCHALTER USA F. SPUELMASCHINE	FLOATING SWITCH USA-TYPE	FLOTTEUR P. NIVEAU DE BAC TYPE USA
5	8302016	SKT-MUTTER R=1/4" SW19X5* MS	HEXAGON NUT RED BRASS R=1/4" SW19X5*	ECROU A SIX PINS R=1/4" SW19X5*
6	0340050	U-SCHEIBE 40X13X3 MM	WASHER 40X13X3 MM	RONDELLE 40X13X3 MM
7	8660312	6KT-MUTTER 1.4301 R1/4"-SW19-7	HEXAGON NUT 1.4301 R1/4"-SW19-7	ECROU A 6 PANS 1.4301 R1/4"-SW19-7

15.01 BANDANTRIEB - ENDSCHALTER



15.01 BELT DRIVE - FINAL SWITCH

15.01 ENTRAINEMENT DE CONVOYEUR - INTERRUPT. FIN DE COURSE

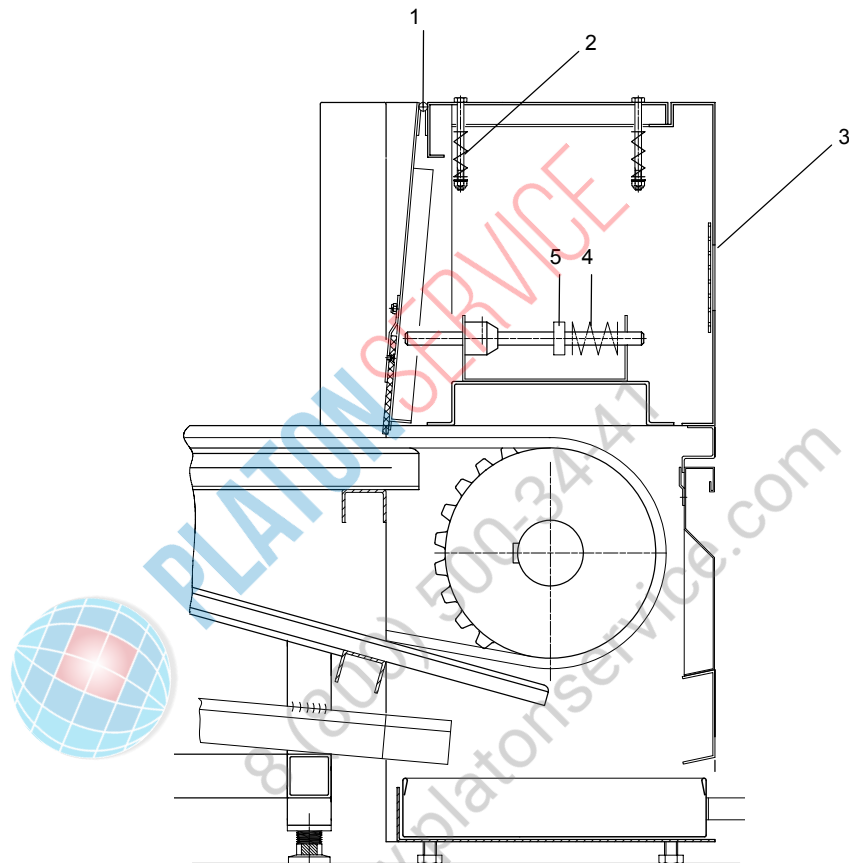

POS	IDENT. NR. IDENT. NO.	BEZEICHUNG	DESIGNATION	DESIGNATION
1	0460004	STANGENSCHARNIER CRNI 40X1,5X3 MM	PIANO HINGE CRNI CRNI 40X1,5X3 MM	CHARNIERE CRNI 40X1,5X3 MM
2	* 0431016	DRUCKFEDER V2A 11 X 50 X 1,75 MM	PRESSURE SPRING V2A 11 X 50 X 1,75 MM	RESSORT V2A 11 X 50 X 1,75 MM
3	8252193	LÜFTUNGSGITTER 4301	VENTILATION GRID 4301	GRILLE D'ASPIRATION 4301
4	* 0431019	DRUCKFEDER V2A 17 X 80 X 1,75 MM	PRESSURE SPRING V2A 17 X 80 X 1,75 MM	RESSORT V2A 17 X 80 X 1,75 MM
5	8660144	STELLRING	FIXING RING	BAGUE DE DISTANCE

16.02 TRANSPORTBAND



16.02 TRANSPORT BELT

16.02 BANDE DE TRANSPORT

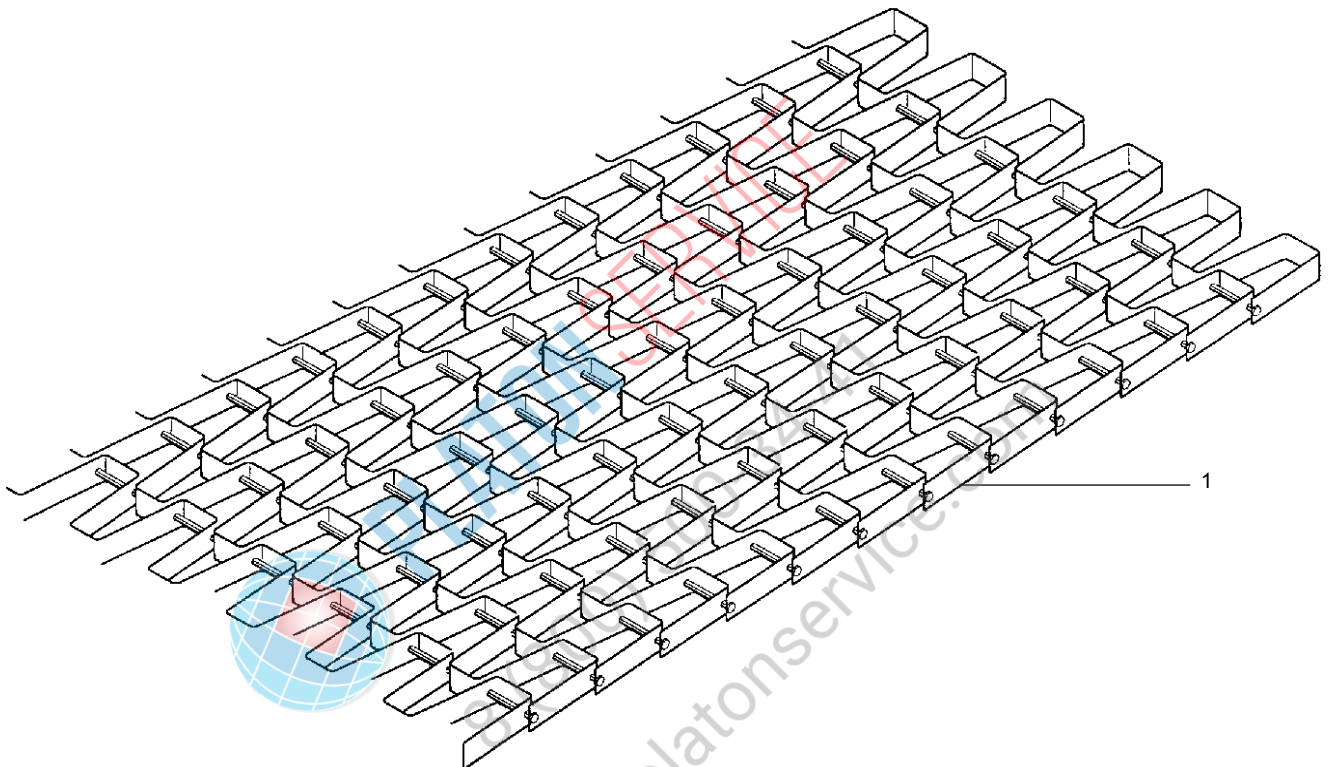

POS	IDENT. NR. IDENT. NO.	BEZEICHNUNG	DESIGNATION	DESIGNATION
-----	--------------------------	-------------	-------------	-------------

1	* 9605771	WABENBAND STRG-27,5X21,8/12,7X1,58-4,9	HONEY COMB CONVEYOR STRG-27,5X21,8/12,7X1,58-4,9	CONVOYEUR A ALVEOLES STRG-27,5X21,8/12,7X1,58-4,9
---	-----------	---	---	--

17.03 BANDANTRIEBE Ø 60



17.03 BELT DRIVES Ø 60

17.03 ENTRAINEMENTS DE CONVOYEUR Ø 60

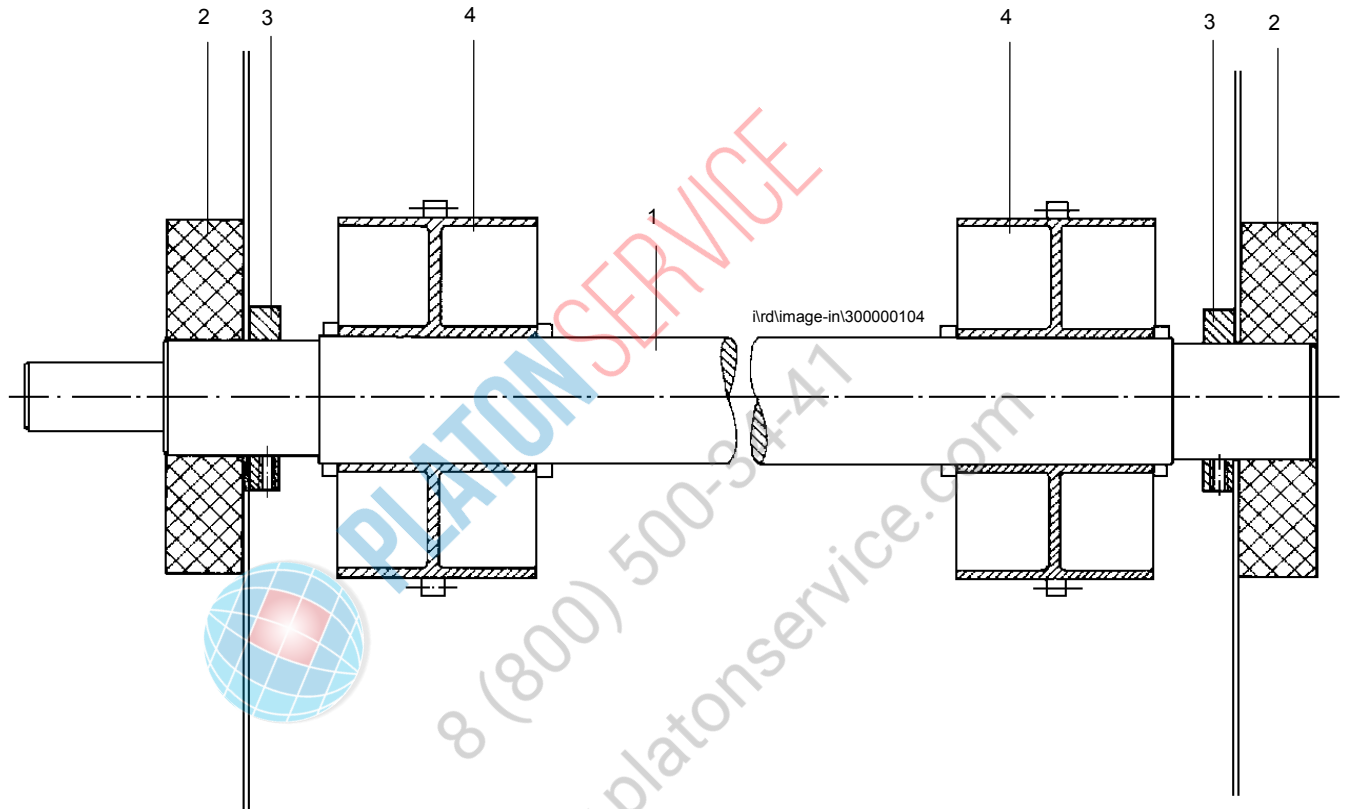

POS	IDENT. NR. IDENT. NO.	BEZEICHNUNG	DESIGNATION	DESIGNATION
1	9605773	ANTRIEBSWELLE D=60 F-STRG BAND	DRIVE SHAFT D=60 F-STRG BELT	ARBRE D'ENTRAINEMENT D=60 F-STRG CONVOYEUR
2	* 8252150	LAGER ANTRIEBSWELLE 180X180X50 -S-	BEARING / DRIVE SHAFT 180X180X50 -S-	PALIER / ARBRE D'ENTR. 180X180X50 -S-
3	8252151	STELLRING D90X60-20 M6 MS	SET COLLAR D90X60-20 M6 MS	BAGUE D'ARRET D90X60-20 M6 MS
4	* 9605772	SCHEIBEN Z=23 KUNSTSTOFF BOHRUNG D=60 MM B=60 MM	DISK Z=23 D=60 MM B=60 MM	DISQUE Z=23 D=60 MM B=60 MM

20.02 KETTENRÄDER

20.02 CHAIN WHEELS

20.02 ROUE DE CHAÎNE

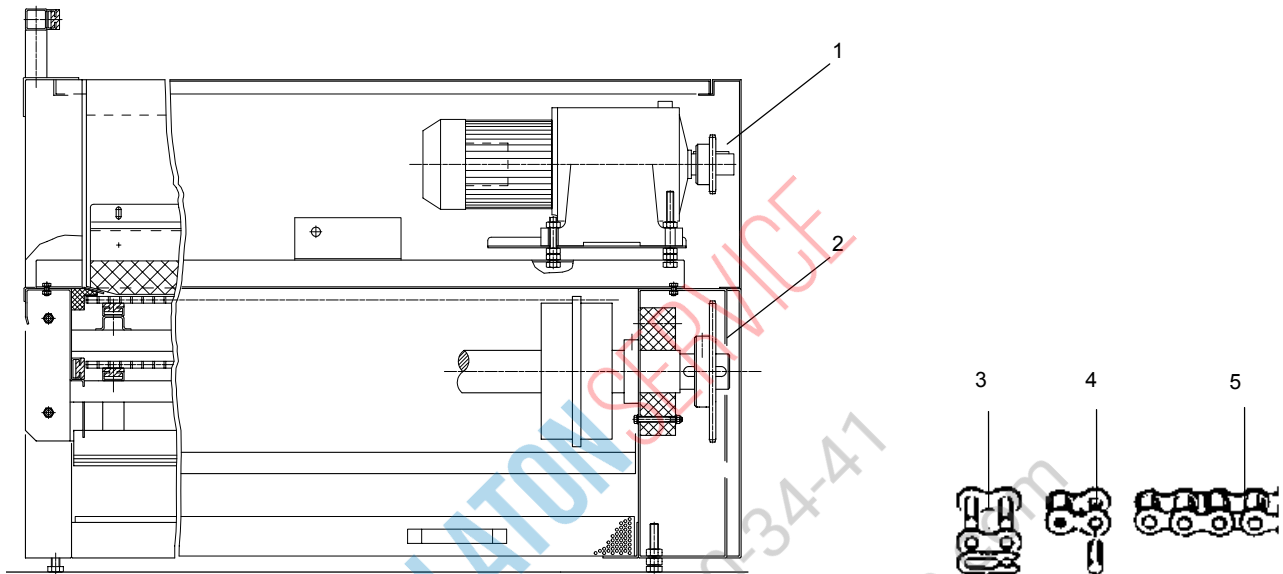

POS	IDENT. NR. IDENT. NO.	BEZEICHNUNG	DESIGNATION	DESIGNATION
		BA 251 C	BA 251 C	BA 251 C
1	0435097	KETTENRAD MIT NUT 5/8" Z15 D25 STVZ	CHAIN WHEEL WITH NUT 5/8" Z15 D25 STVZ	ROUE DE CHAÎNE AVEC RAINURE 5/8" Z15 D25 STVZ
2	9607568	KETTENRAD MIT NUT 5/8" Z40 D 50	CHAIN WHEEL WITH NUT 5/8" Z40 D 50	ROUE DE CHAÎNE AVEC RAINURE 5/8" Z40 D 50
		BA 252 C (V=0,8 M/MIN-1.1 M MIN)	BA 252 C (V=0,8 M/MIN-1.1 M MIN)	BA 252 C (V=0,8 M/MIN-1.1 M MIN)
1	0435097	KETTENRAD MIT NUT 5/8" Z15 D25 STVZ	CHAIN WHEEL WITH NUT 5/8" Z15 D25 STVZ	ROUE DE CHAÎNE AVEC RAINURE 5/8" Z15 D25 STVZ
2	9607567	KETTENRAD MIT NUT 5/8" Z34 D 50	CHAIN WHEEL WITH NUT 5/8" Z34 D 50	ROUE DE CHAÎNE AVEC RAINURE 5/8" Z34 D 50
		BA 252 C (V=1,2 M/MIN-1.6 M MIN)	BA 252 C (V=1,2 M/MIN-1.6 M MIN)	BA 252 C (V=1,2 M/MIN-1.6 M MIN)
1	0435097	KETTENRAD MIT NUT 5/8" Z15 D25 STVZ	CHAIN WHEEL WITH NUT 5/8" Z15 D25 STVZ	ROUE DE CHAÎNE AVEC RAINURE 5/8" Z15 D25 STVZ
2	8254017	KETTENRAD MIT NUT 5/8" Z28 D 50	CHAIN WHEEL WITH NUT 5/8" Z28 D 50	ROUE DE CHAÎNE AVEC RAINURE 5/8" Z28 D 50
		BA 253 C	BA 253 C	BA 253 C
1	0435097	KETTENRAD MIT NUT 5/8" Z15 D25 STVZ	CHAIN WHEEL WITH NUT 5/8" Z15 D25 STVZ	ROUE DE CHAÎNE AVEC RAINURE 5/8" Z15 D25 STVZ
2	9607565	KETTENRAD MIT NUT 5/8" Z23 D 50	CHAIN WHEEL WITH NUT 5/8" Z23 D 50	ROUE DE CHAÎNE AVEC RAINURE 5/8" Z23 D 50
3	* 0435016	KETTENSCHLUSSGLIED 5/8"	CHAIN LOCK 5/8"	ELEMENT FINAL DE CHAÎNE 5/8"
4	* 0435017	KETTENKROEPFGLIED 5/8"	HALF MEMBER 5/8"	ELEMENT DE CHAÎNE ONDULE
5	* 0435015	ROLLENKETTE ST 5/8"	DRIVE CHAIN 5/8"	CHAÎNE A ROULEAU ST 5/8"

Use 30 mm Bore
15 tooth Sprocket
P/N 8260215

1

21.01 BANDSPANNVORRICHTUNG



21.01 BELT TENSIONING DEVICE

21.01 DISPOSITIF DE TENSION POUR BANDE

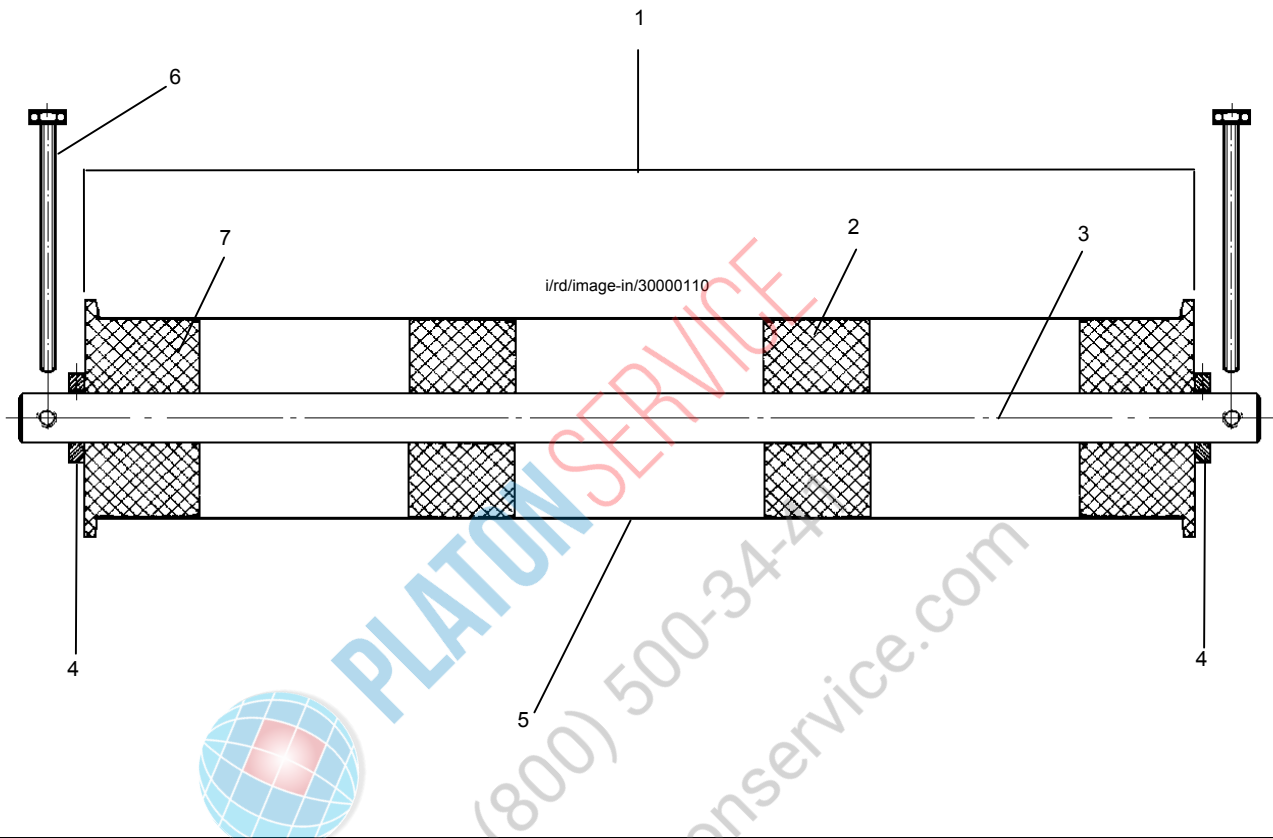

POS	IDENT. NR. IDENT. NO.	BEZEICHNUNG	DESIGNATION	DESIGNATION
1	8252832	SPANNWALZE KPL: (OHNE SPANNSCHRAUBE, OHNE STELLRING)	TENSION ROLLER (WITHOUT TENSION SCREW, WITHOUT FIXING RING)	ROULEAU TENDEUR (SANS VIS DE TENSION SANS BAGUE DE FIXATION)
2	* 8252835	LAGER - SPANNWELLE -S- D=200X100	BALL-BEARING/TENSION SHAFT -S- D=200X100	PALIER ARBRE DE TENSION -S- D=200X100
3	8252833	SPANNWELLE 4301 D=50X1184	TENSION SHAFT 4301 D=50X1184	ARBRE DE TENSION 4301 D=50X1184
4	8252837	STELLRING D90X50-15 M6 MS	FIXING RING D90X50-15 M6 MS	BAGUE DE FIXATION D90X50-15 M6 MS
5	8252836	ROHR - SPANNWELLE 4301 D=204X2X1033	PIPE-TENSION SHAFT 4301 D=204X2X1033	TUYAU-ARBRE DE TENSION 4301 D=204X2X1033
6	* 8252811	SPANNSCHRAUBE 4301 M16X205	TENSION SCREW 4301 M16X205	VIS DE TENSION 4301 M16X205
7	8252834	LAGERBODEN - SPANNWELLE -S- D=238X112	BALL-BEARING/TENSION SHAFT -S- D=238X112	PALIER DE COUSSINETS -S- D=238X112

22.02 ABSAUGGEBLÄSE Ø500

22.02 EXTRACTION FAN Ø500

22.02 VENTILATEUR D'ASPIRATION Ø500



POS	IDENT. NR. IDENT. NO.	BEZEICHUNG	DESIGNATION	DESIGNATION
1		GEBLÄSE AXIAL FÜR WÄRMEPUMPE SIEHE ELEKTROSCHALTPLAN	FAN AXIAL FOR HEAT PUMP SEE ELECTRIC WIRING DIAGRAM	VENTILATEUR AXIAL POUR POMPE A CHALEUR VOIR SCHEMA ELECTRIQUE

23.06 RADIALGEBLÄSE



23.06 RADIAL FAN

23.06 VENTILATEUR RADIAL

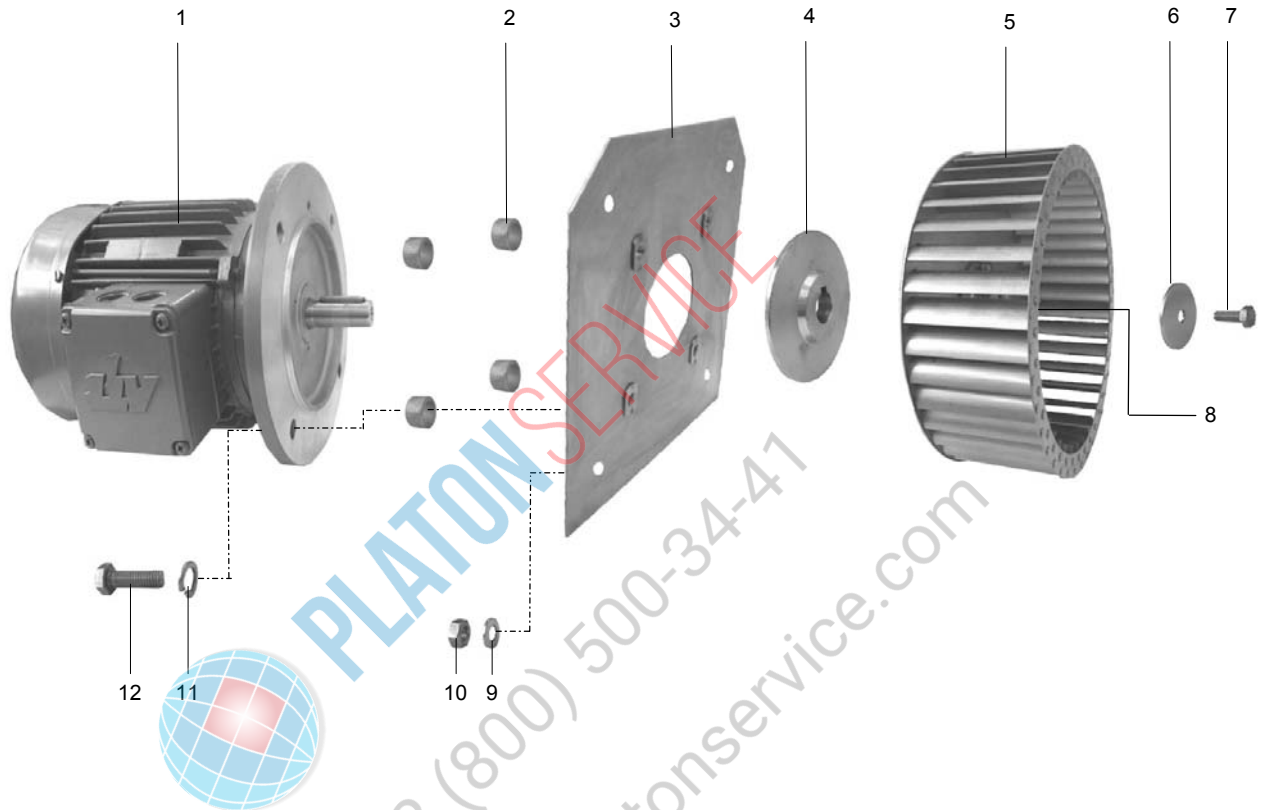

POS	IDENT. NR. IDENT. NO.	BEZEICHNUNG	DESIGNATION	DESIGNATION
1		MOTOR 2,2KW SIEHE ELEKTROSCHALTPLAN	THREE-PHASE FLANGE MOTOR 2,2 KW SEE ELECTRICAL WIRING DIAGRAM	MOTEUR TRIPHASE 2,2KW VOIR SCHEMA ELECTRIQUE
2	8180026	DISTANZ FÜR LÜFTERMOTOR Ø17X10 1.4301	DISTANCE PIECE F. EXTRACTION MOTOR Ø17X10 1.4301	PIECE DE DISTANCE POUR VENTILATEUR Ø17X10 1.4301
3	8130091	MOTORPLATTE FÜR MRL 280X280X2 1.4301	MOTOR SUPPORT F. MRL-FAN 280X280X2 1.4301	PLAQUE SUPPORT DE MOTEUR 280X280X2 1.4301
4	8180027	SCHLEUDERSCHEIBE Ø90X19X11,5 CUZN	CENTRIFUGAL DISC Ø90X19X11,5 CUZN	RONDELLE CENTRIFUGE Ø90X19X11,5 CUZN
5	0550041	LÜFTERRAD 250X100 1.4301	VENTILATOR WHEEL 250X100 1.4301	ROUE DU VENTILATEUR 250X100 1.4301
6	8100251	U-SCHEIBE Ø34X7X2 1.4301	FRONT DISC Ø34X7X2 1.4301	RONDELLE Ø34X7X2 1.4301
7	0302001	SKT.-SCHRAUBE M6X15	HEXAGON SCREW M6X15	VIS A 6 PANS M6X15
8	8180024	NABE FÜR LÜFTERRAD Ø85X35 CUZN	CENTER FOR IMPELLER WHEEL Ø85X35 CUZN	MOYEU POUR L'AILE Ø85X35 CUZN
9	0340006	U-SCHEIBE MS. VERN. 18X8,4X2	WASHER BRASS NICKELED 18X8,4X2	RONDELLE EN LAITON NICKELE 18X8,4X2
10	0335015	SKT.-MUTTER M8	HEXAGON NUT M8	ECROU A 6 PANS M8
11	0341005	FEDERRING A10	FEATHER KEY A10	RONDELLE RESSORT A10
12	0302022	SKT.-SCHRAUBE M10X30	HEXAGON SCREW M10X30	VIS A 6 PANS M10X30